

Interior Innovation Award Cologne
Part of the collection of the Vitra Design Museum
Part of the collection of the Mad Museum NYC

The translucent, semi-spherical I597 wall/ceiling light is composed of uncountable spines that appear clipped at their ends to let pass rays of light and create subtle effects on the wall or ceiling.

Designed by *Fanne*

I597 series

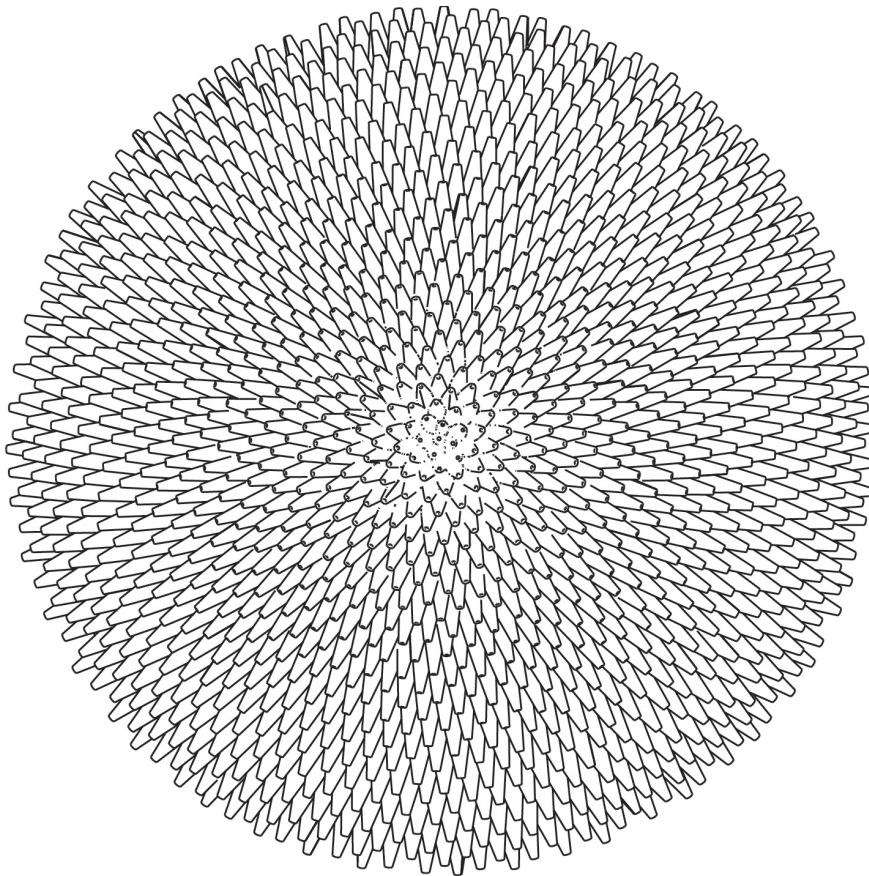

I597 ECO Wall light in Oceania hotel designed by Norman Foster

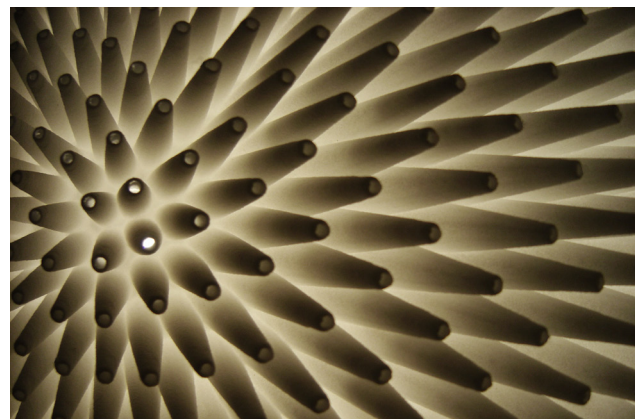

I597 ECO Wall light – front detail

1597

D32/D50/ECO

1597 D32

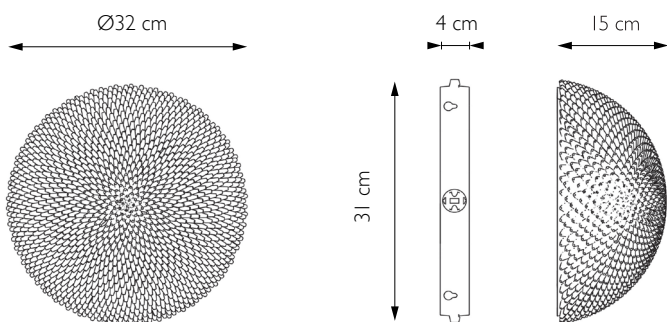

1597 D50

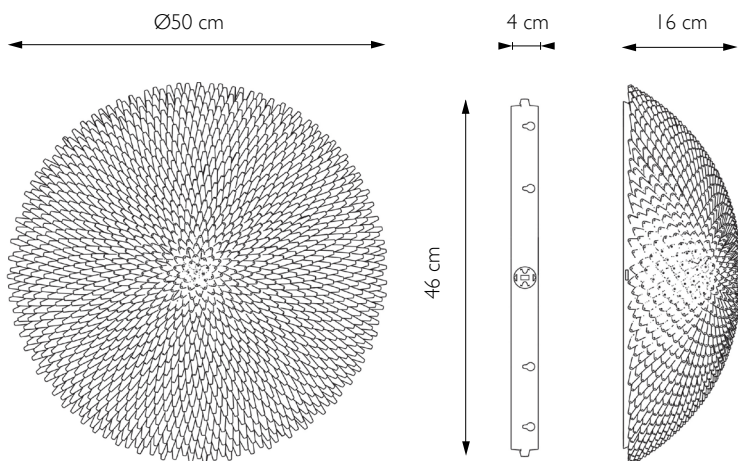

1597 ECO (shade Ø = 1597 D50)

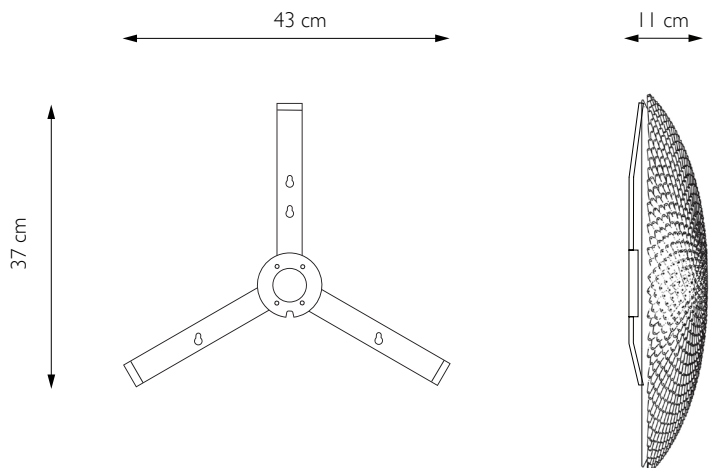

PRODUCT INFORMATION

Product	<input type="radio"/> 1597 D32
	<input type="radio"/> 1597 D50
	<input type="radio"/> 1597 ECO
Bulb	<input type="radio"/> 240V
	<input type="radio"/> 120V

1597 D32 & D50: G9 halogen (Max 48W) supplied
1597 ECO: GX53 CFL (13W) supplied

Type	Sconce; wall or ceiling light
Designer	Janne Kyttänen 2005–2008
Color	White
Material	3D printed Nylon

HOW IT'S MADE

This product is the outcome of Freedom Of Creation's ten years of pioneering research exploring 3D printing technologies; a process that transforms a CAD file into a real object by a printing process, adding one layer of matter onto the other until the entire object is generated. The unlimited expressive possibilities that these technologies provide have characterized FOC as a trendsetting brand.

INSTALLATION INSTRUCTION

Step 1a (1597 D32 & D50) – You can either leave the cable hanging against the wall and use the dimmer/switch or cut the cable and connect it directly to your power source (make sure that the electricity is switched off) **Step 1b** (1597 ECO) – Connect to your power source by unscrewing the white terminal block or by stripping the cable (shorter)
Step 2 – Connect the mounting unit to the wall or ceiling with the screws & plugs (use M6 drill) that are included
Step 3 – Insert the bulb in the ceramic fitting
Step 4a (1597 D32 & D50) – Snap the shade onto the mounting unit connectors **Step 4b** (1597 ECO) – Flex the shade into the 3 connectors of the mounting unit

DAILY USE INSTRUCTION

Light placement
– Only indoors
– Do not use as a table light
– Press the dimmer button once to turn the light on/off. Hold the button to dim/brighten the light (Only 1597 D32 & 1597 D50)
Bulb (re)placement
– Do not (re)place when the cable is plugged into the socket
– Do not touch halogen bulbs with your bare hands (Only 1597 D32 & 1597 D50)
– Do not use bulbs that exceed the maximum wattage specified in the right top of the sheet
Precautions
– Do not cover the lamp
– Do not leave the product unattended with children
– The product is not a heavy duty item but a work of art, so treat it carefully
Cleaning
The shade can be cleaned with standard soap and a dishwashing brush or it can be placed in the dishwasher

COLOR CHANGE

Just like people the color of the 3D-Printed shade ages. It comes out white and will become a stable off-white color after a year

ELECTRICITY MARKINGS



DIMENSIONS

	Package dimensions	Net/gross weight
1597 D32	43 x 43 x 27 cm	0,5 / 3 kg
1597 D50	57 x 57 x 25 cm	1,1 / 4 kg
1597 ECO	57 x 57 x 25 cm	1,0 / 4 kg